

## Preface

Thank you for choosing 5KW water parking heater

This instruction book describes the structures, working principles, installation and operation of the parking heater. For correct use of the heater, please read this instruction book carefully before installation and use. The instruction book shall be saved in a convenient place for later reference.

### **Attention:**

- This instruction book is subject to revision without notice, but the instruction book is in conformity to the purchased product.
- Our effort is to explain all questions the users may have through this instruction book. If you have any doubts or find anything incorrect in this instruction book, please contact our company directly.
- At first unpacking, please check the heater and its accessories against the packing list. Please contact the dealer immediately if any problem is found.
- If any trouble arises during application, please contact the Department of Marketing of our company or other customer service stations authorized by this company. We shall do our best to provide service to you.

# CONTENTS

1	Introduction	3
2	Main Technical Specifications	3
3	Structures and Working Principles	4
4	Installation	6
5	Methods of Operation	16
6	Treatment of Usual Troubles	20
7	Precautions	20
8	Packing List	25

## Note:

Comply with the operational manual for installation and use to ensure that the heaters can work for a long time.

Version No.: 20150725

## 1 Introduction

The main equipment of environmental protective and highly intelligent remote control parking heater (hereinafter referred to as the heater) is a small fuel furnace controlled by a single-chip microprocessor. Its medium circulation system is connected with the cooling system of automobile engine. In such a way, the cooling liquid for engine can be heated by the heater while the engine is not working, so as to increase the temperature of the engine and the interior of automobile. The engine is made easy to start even at very low temperature and both the drivers and passengers can have a warmer environment.

The heater is fully automatically controlled for heating. It features in compact structure, small volume, remote control, energy-saving, environmental protection, dual security system, convenient installation, easy maintenance, etc.

## 2 Technical Specifications

Heating medium	Coolant	
Thermal power (W)	High power operation:5000W	
	Low power operation:1500W	Low power operation:2400W
Fuel	Gasoline	Diesel
Fuel consumption (l/h)	High power operation:0.69 l/h	High power operation:0.62 l/h
	Low power operation:0.2 l/h	Low power operation:0.27 l/h
Power supply (Common battery for the engine)	DC12V	DC12/24V
Power consumption (W)	at starting<100 37 for high power operation and 10 for low power operation.	
Working pressure(Mpa)	0.25	
Lowest working temperature	-40℃	
Net Weight (Only heater)	4.8kg	
Working height above sea level	≤1500m	
Mobile phone control (Optional)	No limitation	
Weight of Main Heater (kg)	2.6kg	
Mobile phone control (Optional)	No limitation (GSM network coverage)	
Remote control (Optional)	Without obstacles≤800m	
Temperature of coolant when warm blower is started	45℃	

## 3 Structures and Working Principles

The structures of the heater are shown in Fig. 1. (Without filter and damper )

### 3.1 Cooling Liquid Circulation System

The cooling liquid of engine flows through water inlet pipe 19, the furnace cavity between the furnace inner casing 3 and outer casing 2, and water outlet pipe 18, forming a complete loop for the cooling liquid circulation system. The circulation is forced by water pump 13. In this way, the cooling liquid of engine can be heated again and again in the furnace and the temperature of engine, water-tank, heat-exchanger and cab can rise gradually.

The car should be started first for circulating the coolant after installation. Switch the A/C to warm blower mode, the bubbles can be eliminated after the warm air blows

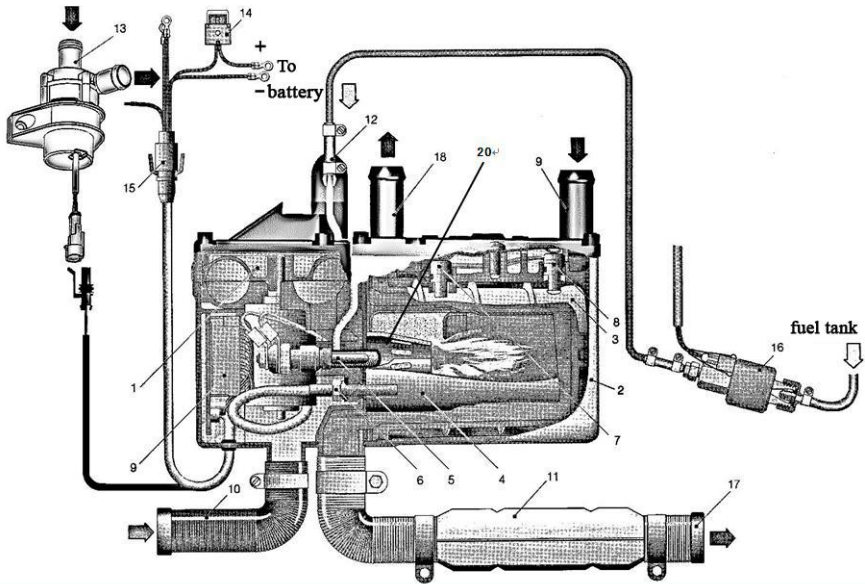

Fig. 1

- 1.Combustion supporting fan    2.Furnace outer casing    3.Furnace inner casing  
 4.Combustor    5.Glow plug    6.Flame sensor    7.Water temperature sensor  
 8.Overhear sensor    9.Controller    10.Air inlet pipe    11.Muffler    12.Fuel pipe  
 connector    13.Water pump    14.Fuse    15.Main wire harness connector    16.Fuel  
 pump    17.Exhasut pipe    18.Water outlet pipe    19.Water inlet pipe    20.Burner

Burner is wearing part which suggested that changing once every 800 hour  
 s.

## 3.2 Furnace

The main body of furnace consists of furnace outer casing 2, furnace inner casing 2, combustor 4, etc. Fuel pump 16 draws fuel from fuel tank and send it to combustor to mix with combustion supporting air. The mixture is to be ignited by glow plug 5. The fresh air from air intake pipe 10 is blown into combustor by combustion supporting fan 1 for sufficient burning. The exhaust gas, after flowing is to be released to the air through muffler 11 by the exhaust pipe 17.

## 3.3 Controller

Control and monitoring on working conditions of the heater is carried out by the single-chip microprocessor-based controller 9 according to preloaded programs. The control and monitoring tasks are in the below:

Monitor the voltage of power supply and to decide if it can meet the requirements of work.

- (1) Check if there is any open circuit or short circuit trouble with the combustion supporting fan, water pump, glow plug, flame sensor, overheating sensor, water temperature sensor, etc. before and during normal operation of the heater.
- (2) Carry out control on voltage of power supply、 conduction time and duration time of the glow plug.
- (3) Carry out control on speed of rotation of the combustion supporting fan in heater's different phases of working.
- (4) Adjust fuel feeding rate of fuel pump automatically according to heater's different phases of working.
- (5) Determine (or adjust) working conditions of heater according to data collected from flame sensor, overheating sensor and water temperature sensor.
- (6) Switch off the equipment automatically if some troubles arise during working. The equipment can be switched on again if necessary. But if the equipment has been switched off for more than a fixed number of times, the equipment will be locked and cannot be restarted. The instrument can only be put into use after the trouble is analyzed and solved by the troubleshooting and diagnosis instrument.

## 3.4 Sensors and Safety Protection

3.4.1 The flame sensor 6 is used to measure the temperature of the combustion chamber so as to judge if the combustion chamber has been ignited and keeps burning after the ignition.

3.4.2 The overheating sensor 8 is used to measure the temperature of the furnace inner casing. The heater will be shut down automatically in case of overheating due to inadequate water in furnace cavity or other troubles.

3.4.3 The water temperature sensor 7 is used to measure the temperature of the cooling liquid and determine whether the warm blower of the heat exchanger in the car needs to be started and also determine the working conditions of the heater.

### 3.5 On/Off Operation

Switching on or off of the heater can be completed by a mini-meter or remote control unit or GSM control units. Any other ways (shut off)power off the heaters are not allowed.Please refer to Chapter 5 Methods of Operation for details.

### 3.6 Power Supply

The power supply to the heater is the storage battery in the automobile. The power supply is with an independent security control device. Parking heater working time can't more than driving time everyday or the battery will be lack of electric(Need charge battery in time).Battery of more than 2 years which loss electric frequently should be changed by a new one in order to ensure normal use of parking heater.

### 3.7 Fuel Supply

The fuel for the heater can be from the fuel tank for driven automobile, a 5 L fuel tank can be for selection also.

## **4 Installation**

Only special-purpose parts as shown in Fig. 2 can be used for installation of the heater. The positions and ways of fixing of various parts may vary from one automobile model to another, but the general principles shall be in conformity to the requirements of this chapter.

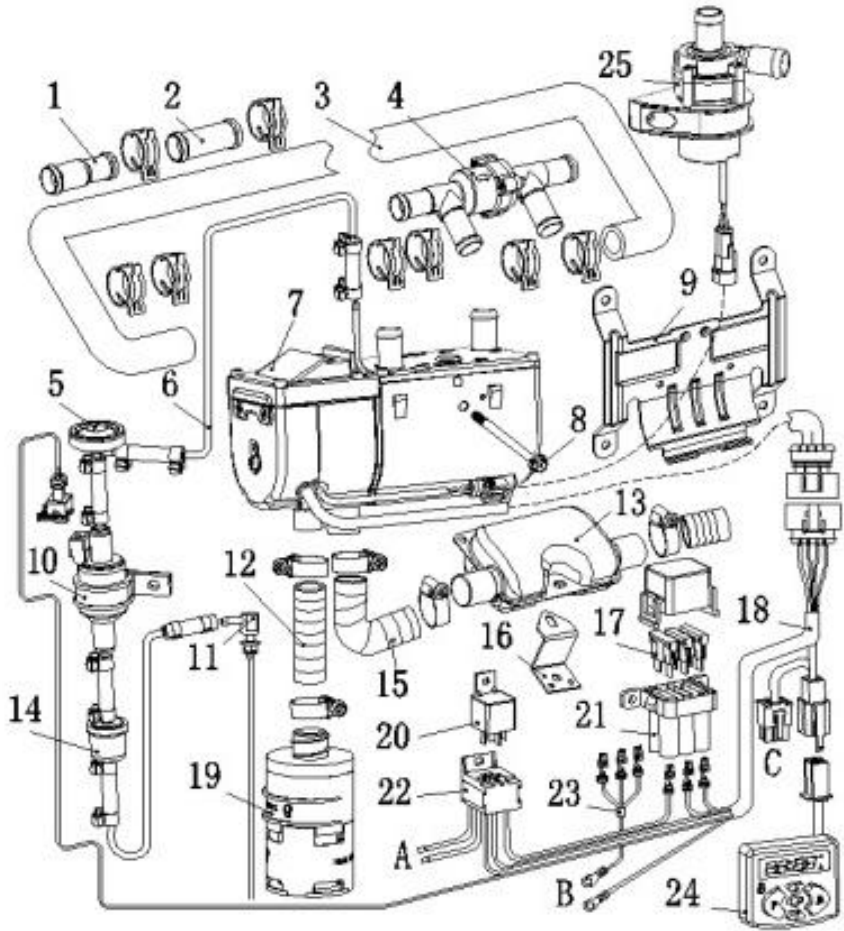

**Fig.2**

- 1- Water pipe joint 2- Water pipe joint 3- Water pipe 4- Non-return valve 5- Damper 6- Fuel pipe  
 7- Heater 8- Fixing bolt for heater 9- Bracket for the heater 10- Fuel pump 11- Fuel suction pipe  
 12- Air inlet pipe 13- Muffler 14- Filter 15- Exhaust pipe 16- Muffler holder 17- Fuse  
 18- Main wire bundle 19- Air filter 20- Relay for warm blower motor 21- Fuse holder 22- Socket of relay  
 23- Connect positive pole of power supply 24- Mini timer 25- Water pump  
 A-Connect warm blower motor  
 B-Connect positive pole of power supply  
 C-Connect negative pole of power supply  
 D-Connect control devices(timer,remote control and manual button)

#### 4.1 Installation Site and Use of Heater Requirements

4.1.1 It is not allowed to use the heater in locations with inflammable or explosive substances such as flammable gas or flammable dust.

4.1.2 It is not allowed to use the heater in closed space (such as garage) to avoid danger of poisoning by exhaust from burning.

4.1.3 It is not proper to install and use the heater in house.

4.1.4 It is not allowed to use the heater in passenger compartment, cab or any other space where people are staying.

4.1.5 If the heater is installed in special-purpose vehicles (such as vehicles for dangerous goods), special rules must be followed.

4.1.6 Pay attention not to place fuel tank, gasoline tank, compression tank, fire extinguisher, clothes, paper, etc. near the heater.

#### 4.2 Installation of the Main Equipment

The dimension of the heater is shown in Fig. 3.

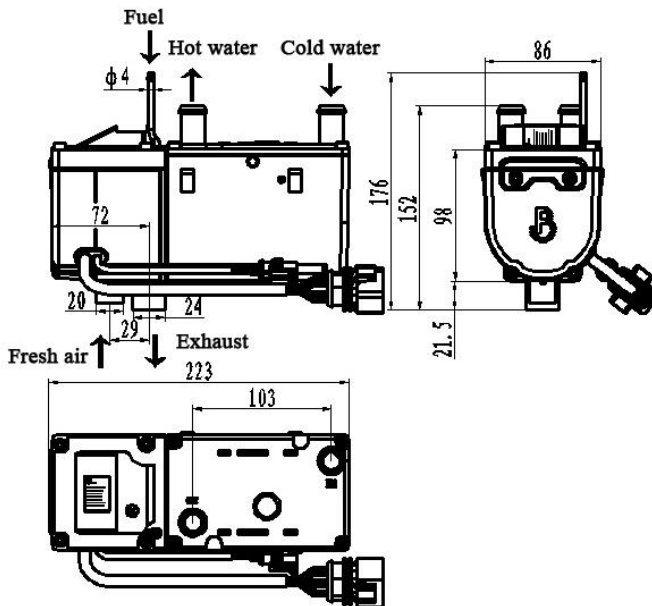

Fig. 3

**Any consequences caused by not installing according our requirement we don't afford any responsibility.**



4.2.1 The main equipment of the heater is mounted on automobile with a bracket. Fasten the heater bracket firmly first, four corners should pad with rubber shock absorbers. In order to save installation space, can insert the M6 bolts into the fixed holes of parking heater, then hanging the heater on the support toggle hook, finally the M6 bolts tightening in the threaded holes of parking heater.

4.2.2 The heater shall be installed in the engine chamber as deeply as possible, so as to facilitate heat conduction and enable the water pump to evacuate air automatically. Choice of installation location should consider the water pipe used as short as possible, an additional water pipe is not allowed, otherwise it may affect normal work of warm air blower.

4.2.3 Choice of position for installation of the heater shall facilitate release of air from the water pipe. It is allowed to incline to suit different arrangements for installation, but deviation from the “normal installation position” shall not exceed 90°, as shown in Fig. 4. Normal position is horizon and the exhaust pipe vent down.

4.2.4 Water outlet of heater can replace for elbow according to the the requirements, the o-ring must be replaced at the same time.

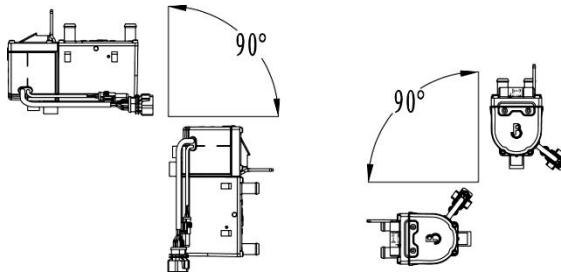

Fig. 4

#### 4.3 4.3 Installation of Cooling Liquid Circulation System(As show in Fig.5)

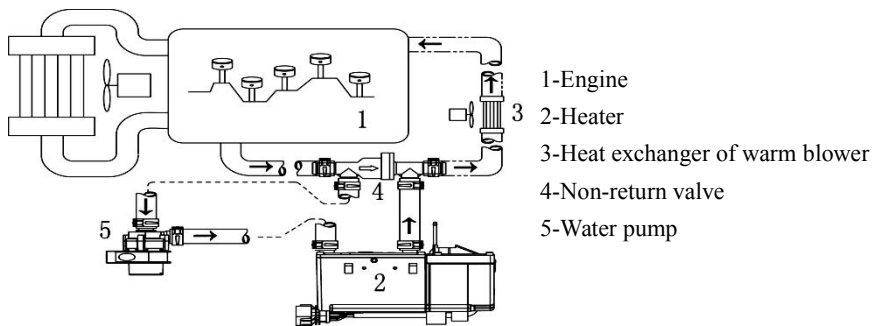

Fig. 5

4.3.1 Use special-purpose rubber pipe and pipe clamps to connect the main equipment of the heater between the automobile engine and the hot-air exchanger. Arrow direction of non-return valve should be consist with engine flow,can not put wrong.

4.3.2 Water pump inlet should below the water outlet in order to eliminate air when installing water pump

4.3.3 Filling with full of cooling liquid in the heater water pipe before connecting heater water pipe and car water pipe,then connecting with car water pipe and fill with full of cooling liquid in the circling system in the end.

**Attention: The cooling liquid in use must be in conformity with the specifications of the automobile manufacturers. Anti-freezer not only can improve anti-freezing quality of the cooling liquid, but also can prevent corrosion. Therefore water can not be added in any case and only cooling liquid can be replenished.**

4.3.3 At installation, the existing cooling liquid in automobile must be evacuated and use clean water to rinse the system. Then, new liquid can be filled in. If you want to use the original cooling liquid, you have to clean it with a filter. In addition, the content of anti-freezer must be in conformity with the requirement of Article 4.3.2.

If a used heater is to be installed in other vehicles, please use clean water to rinse the inner cavity of the cooling liquid circulation system of the heater.

#### 4.4 Installation of Air Intake and Exhaust System

Installation of air intake and exhaust system is shown as Fig. 6. The air inlet pipe and exhaust pipe must be the special-purpose parts, and are not supposed to cut short. The middle sections of the pipes shall be fixed with clamps (special-purpose parts, two of each) in proper locations.

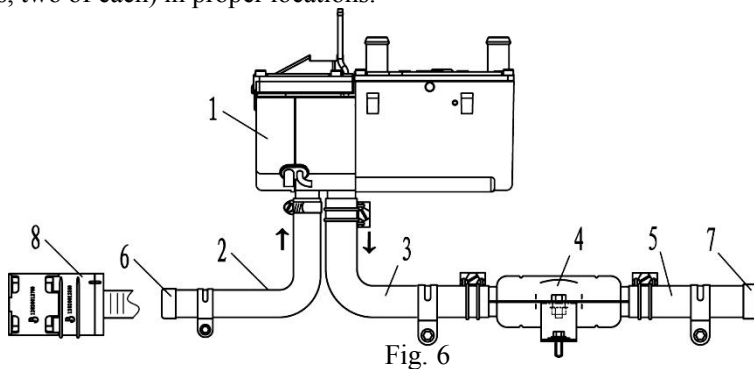

1- Heater 2- Air inlet pipe 3- Exhaust pipe 4- Muffler  
5- Exhaust tail-pipe 6-and 7-protective hoods 8-Air filter

4.4.1 The function of the air inlet pipe is to draw combustion supporting air into the main equipment for the furnace. the vent of the air inlet pipe shall not be opposite to the air flow, and shall not be plugged by dust, rain or snow. The protective hood at the vent shall not be damaged.

4.4.2 The special-purpose exhaust pipe shall be cut off in proper position to form two sections: an exhaust pipe and an exhaust tail-pipe. The muffler shall be positioned in the middle and fixed with the muffler holder.

**Attention: Exhaust parts are at high temperature when the heater is working. They shall be arranged far from the plastic parts and wires of the vehicle to avoid damage.**

**Air inlet pipe and exhaust pipe is easy to freeze in working condition and should always check whether unobstructed.**

4.4.3 The exhaust (tail-) pipe shall not extrude out of the automobile contour. Its outlet position shall prevent intake of the exhaust by the air inlet pipe or convection fan (or far from the air inlet pipe and the air intake vent of the convector fan). Its outlet shall not be opposite to the air flow, and shall not be plugged by dust, snow or rain. The protective hood at the outlet shall not be damaged.

A small hole (  $\phi 2\sim 5$  ) shall be drilled at the low end of the exhaust pipe for condensate to drain.

#### 4.5 Installation of Fuel Supply System

The fuel supply system for the heater is as shown in Fig.7. Damper installation should be according to the practical situation.If the packing list doesn't include the damper then it is should not be used temporarily.

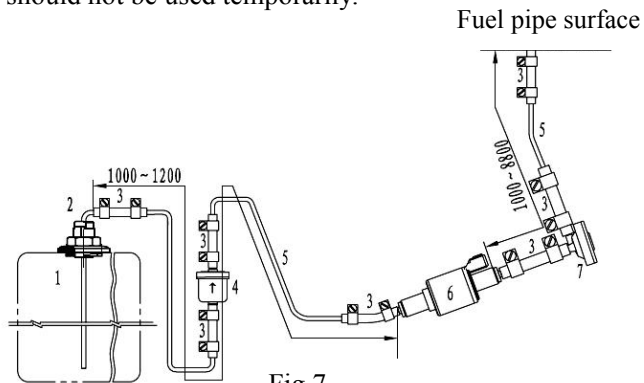

Fig.7

1.Fuel tank 2.Fuel extractor 3.Fuel pipe connector 4.Filter 5.Fuel pipe 6.Fuel pump 7.Damper

4.5.1 The fuel pump shall be fixed in automobile with a fuel pump clamp with

protective rubber cover. The outlet of the fuel pump shall tilt upwards. The tilt angle can be selected from the range of  $15^{\circ} \sim 35^{\circ}$  (as shown in Fig. 8). When conditions permit, the fuel pipe between the fuel pump and the heater shall go up gradually.

4.5.2 The hole on the fuel tank cover is  $\phi 6 \pm 0.1$  for installation of the fuel drawing pipe. The hole shall be made smooth without any burrs on the verge. An O-ring shall be placed beneath the fuel pipe seat. The low port of the fuel drawing pipe shall be about  $30 \sim 40$  mm from the bottom of the fuel tank. (The length of pipe can be truncated or bending, but the pipe line can't be influenced). If it is too low, it becomes liable to suck the precipitating impurities from the bottom of the fuel tank and send into the fuel pipe.

4.5.3 Difference in elevation between the level of fuel and the fuel pump as well as the difference in elevation between the fuel pump and the fuel feeding port of the main equipment (see Fig.8) can produce pressure (or suction) in the fuel pipeline. So, these dimensions shall conform to the requirements as follows:

$a \leq 3\text{m}$ ;  $b \leq 0.5\text{m}$ ; (Avoid of negative pressure may be produced in sealed fuel tank. In such case,  $b \leq 0.15\text{m}$ );  $c \leq 2\text{m}$ .

Note:

1. Please check the vent on the fuel tank when doing installation
2. Fuel pipe after clipping (must use blade, Scissors or pliers are forbidden) should ensure not affect fuel flow amount.

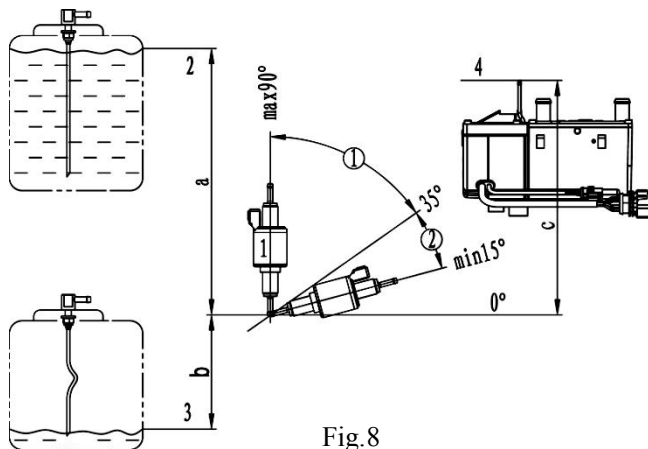

Fig. 8

1-Fuel pump      2-Max.fuel level      3-Min.fuel level      4-Fuel inlet level

① Allowable installation angle

② Optimum installation angle

#### 4.5.4 Installation of fuel filter

Fuel filter should be installed before the fuel inlet of fuel pump, flow direction mark "A" should be correct when doing installation. The installation position of fuel filter should accord with requirement of Fig.9.

**Fuel filter should be changed after 2 years, fuel pipe and clamps should also be changed.**

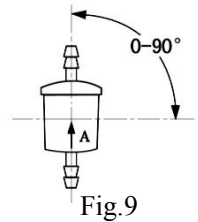

Fig.9

4.5.5 Connect fuel pipe, fuel pump, fuel inlet pipe of the heater and fuel extractor with fuel pipe joint which made of rubber. The connecting place shall be tight without any gap (as shown in Fig. 10). Therefore, the ends of the fuel pipe shall be cut off evenly with a sharp blade to make smooth ends.

Connections are not allowed on the fuel pipe from the fuel pump to the heater.

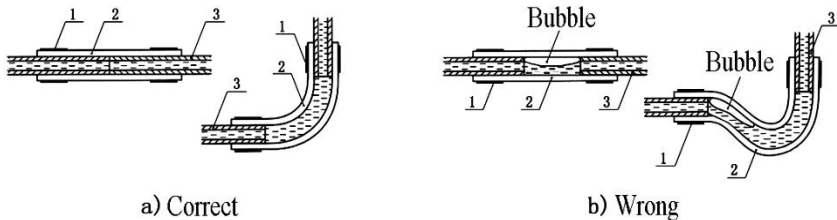

Fig.10

1-Fuel pipe clamp 2-Fuel pipe joint 3-Fuel pipe

4.5.6 Fuel pump and fuel pipes shall keep a distance from any heat source. They should not be installed close to the muffler or exhaust pipe. Fuel pipes shall be protected with thermal insulating material (corrugated pipe should be prepared by dealers).

4.5.7 The fuel pipes shall be fixed in place with ties in proper locations. The distance between two ties shall not be longer than 50 cm.

#### 4.6 Installation of Electrical Parts

The wiring diagram for the heater (using DC 12V as example) in Fig. 11.

4.6.1 The wires of the main equipment of the heater for connection to outside circuits have been made into wire bundles. They can be laid according to the positions of various components and shall be fixed in some proper locations. The distance between two fixing points shall not exceed 30 cm. Attention: Any exposed wire bundle out of the automobile body or out of the wiring groove must be protected by corrugated pipe.

4.6.2 The positive line (4mm<sup>2</sup>, red) of power supply of the heater shall be connected to the positive terminal of the battery of automobile. The negative (ground) line (2.5 mm<sup>2</sup>, brown) shall be connected to the negative terminal of the battery of automobile.

4.6.3 Wire connections of the relay for the warm blower : The black wire of 4 mm<sup>2</sup> shall be connected to the fuse case of automobile. The black/purple wire of 4 mm<sup>2</sup> shall be connected to the “+” terminal of the warm blower .

4.6.4 All electrical components of the heater shall be connected to the wire bundles through connectors. You just need to plug in to make connections according to their corresponding relations.

4.6.5 For those components whose connecting wires may need to go through small holes (such as mini-meter and remote control receiver), you need to pass the wires through the holes before the connection is made to the connector. For such reason, the terminals of these components are not plugged in the sockets in the factory. You have to plug in the terminals according to Fig. 11. You have to keep correct relations for them. Connector for the remote control receiver: Plug connection shall be made according to wire color and serial number of terminals on the sockets. Connector for the mini-meter: Plug connection shall be made according to Fig. 12.

**Attention: All terminals shall be plugged in, even for those above-mentioned components not in use, to avoid any short-circuit.**

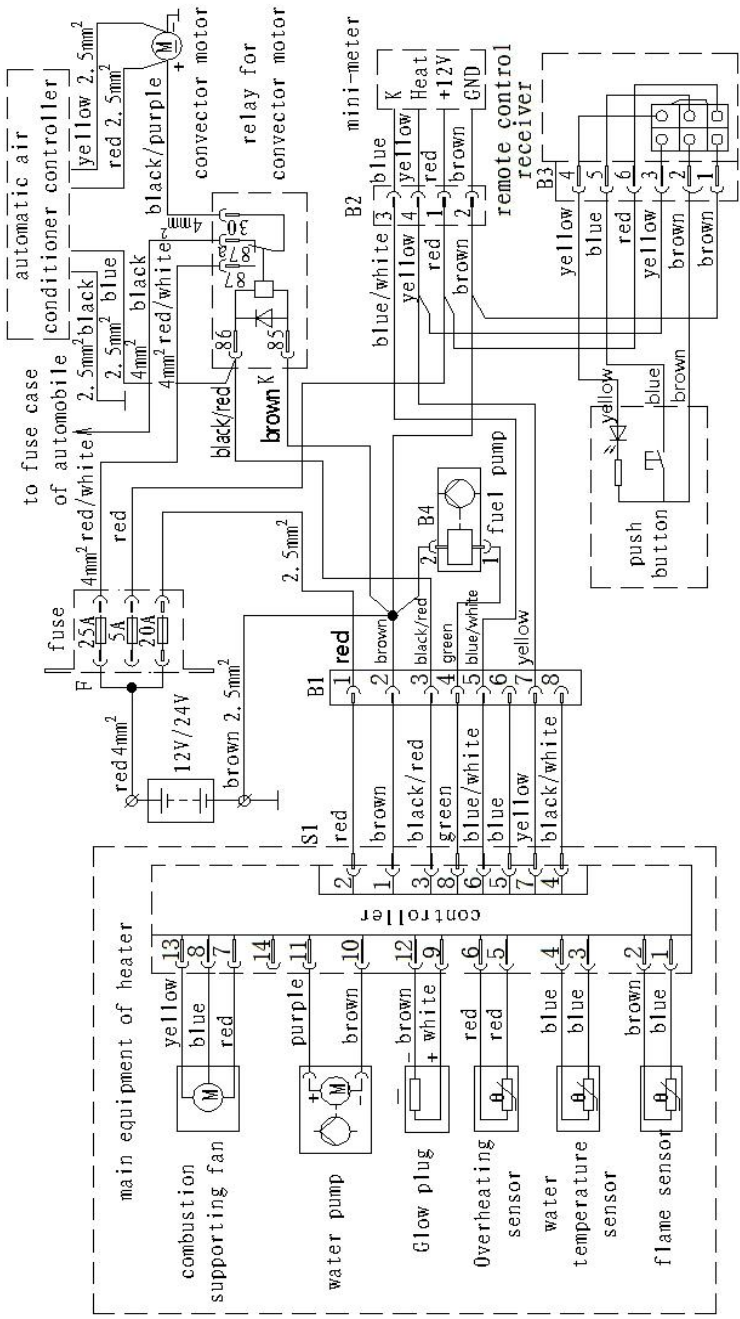

Fig.11

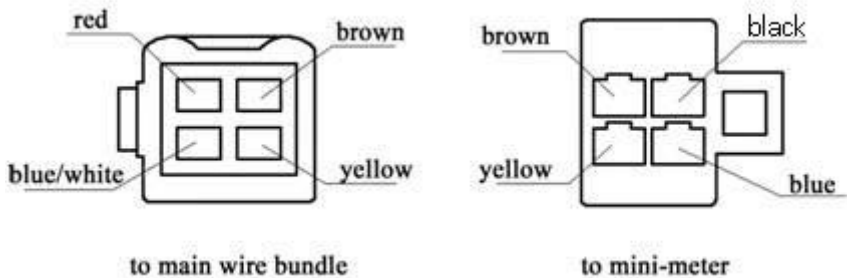

Fig. 12

connector must plug in the jack position and insert according to color is not allowed.

## 5 Methods of Operation

5.1 The heater is operated by timer or a remote in the cab. The remote control unit consists of two parts: remote control receiver and remote controller (or cellphone). The receiver is installed inside the automobile. The transmitter is carried by the user for remote operation within a valid range.

5.2 The main modes of control on the heater include:

5.2.1 Manual power-on and manual power-off.

5.2.2 Manual power-on and automatic power-off when working time has come to a preset length.

5.2.3 Automatic power-on at preset time and automatic power-off when working time has come to a preset length.

5.3 Before turning off the engine, you should set the A/C as the warm air mode and keep I or II gear for the manual A/C, keep the A/C in “Open” position for automatic A/C. In such a way, it is convenient for heating the compartment next time.

5.4 Instructions to Operation of Timer

5.4.1 Panel functions

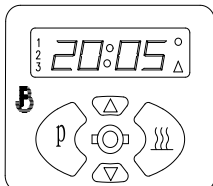

**Key P:** switching between functions.

**Key** : To confirm or cancel the settings.

Immediate power-on or power-off.

**Keys** and : To increase or decrease time,

increase or decrease display brightness.



**Attention:** When power is switched on to the heater, the timer will display  $\overset{1}{88}:\overset{2}{88}\overset{3}{88}\overset{\circ}{\Delta}$ . If no further operation is given, such state will keep unchanged. During such period, keys  $\Delta$  and  $\nabla$  can be used to adjust display brightness.

#### 5.4.2 How to set the present time

5.4.2.1 Press key **P**, the screen will display  $12:00$ . Now you can use keys  $\Delta$  and  $\nabla$  to adjust display brightness.

5.4.2.2 Pressing key **P** one more time, the characters for hour are blinking. You can use keys  $\Delta$  and  $\nabla$  to adjust the time to the present time.

5.4.2.3 Pressing key **P** again, the characters for minute are blinking. You can use keys  $\Delta$  and  $\nabla$  to adjust the time to the present time.

#### 5.4.3 How to preset power-on time

Each day, three power-on times can be preset, represented by the three small digits 1, 2 and 3 on the left of the screen.

##### **5.4.3.1 Presetting the first power-on time:**

5.4.3.1.1 Press key **P**. The display shows small digit “1” and  $6:00$ . The characters for hour are blinking. Use keys  $\Delta$  and  $\nabla$  to adjust the hours for the power-on time.

5.4.3.1.2 Press key **P** again. The characters for minute are blinking. Use keys  $\Delta$  and  $\nabla$  to adjust the minutes for the power-on time.

5.4.3.1.3 Press key  $\llcorner$ , and “●” is displayed on the top right corner of the screen. It is confirmation to the set time.

##### **5.4.3.2 Presetting the second power-on time:**

5.4.3.2.1 Press key **P**. The display shows small digit “2” and  $12:00$ . The characters for hour are blinking. Use keys  $\Delta$  and  $\nabla$  to adjust the hours for the power-on time.

5.4.3.2.2 Press key **P** again. The characters for minute are blinking. Use keys  $\Delta$  and  $\nabla$  to adjust the minutes for the power-on time.

5.4.3.2.3 Press key  $\llcorner$ , and “●” is displayed on the top right corner of the screen. It is confirmation to the set time.

##### **5.4.3.3 Presetting the third power-on time:**

5.4.3.3.1 Press key **P**. The display shows small digit “3” and 18:00. The characters for hour are blinking. Use keys  $\Delta$  and  $\nabla$  to adjust the hours for the power-on time.

5.4.3.3.2 Press key **P** again. The characters for minute are blinking. Use keys  $\Delta$  and  $\nabla$  to adjust the minutes for the power-on time.

5.4.3.3.3 Press key  $\lll$  and “●” is displayed on the top right corner of the screen. It is confirmation to the set time.

5.4.4 How to preset heating time.

Heating time can be set between 1 minute and 1 hour 59 minutes.

5.4.4.1 After the power-on time is set, press key **P**. The screen will display 0:30 ▲. Now the characters for hour are blinking. Use keys  $\Delta$  and  $\nabla$  to adjust the hours for heating time.

5.4.4.2 Next press key **P** again and the characters for minute are blinking. Use keys  $\Delta$  and  $\nabla$  to adjust the minutes for heating time.

5.4.4.3 Press key **P** again. The present time is displayed on the screen again. The three small digits 1, 2 and 3 will be displayed on the left of the screen, indicating three automatic power-on times have been preset.

5.4.5 Immediate power-on and power-off.

5.4.5.1 In the state when the present time is displayed on screen, when you press key  $\lll$ , characters 0:30 ▲ are displayed on the screen. That means the heater has been started. The heating time can be adjusted to be between 1 minute and 1 hour 59 minutes immediately. With the passage of time, the time displayed on the screen will decrease too, until zero, and the heater is switched off automatically at last.

5.4.5.2 If you want to switch off the heater immediately, you can press key  $\lll$  to switch off the heater immediately. The present time will be displayed on the screen.

5.4.6 Checking and eliminating fault code.

Press key **P** in the heating mode, 6 pieces of breakdown information XEXX will be displayed on the screen, X indicates the breakdown number, XX indicates the failure code (Fault code see page 27). Use key  $\Delta$ 、 $\nabla$  to look at the failure information. Hold down key **P** and then press key  $\lll$ , all the failure information will be eliminated. Press key  $\lll$  the screen will go back to display the present time.

**Note:** Please press the key within 10 seconds, after 10 seconds the screen will

**go back to display the time automatically and enter the power save mode state.If no operation within 10 seconds at the present time state,the timer will also enter the power save mode automatically.**

#### 5.4 Remote controller (Optional function See Fig.13)

Power on and power off heater,three times

Can be seted:15mins,30mins and 45mins immediately.

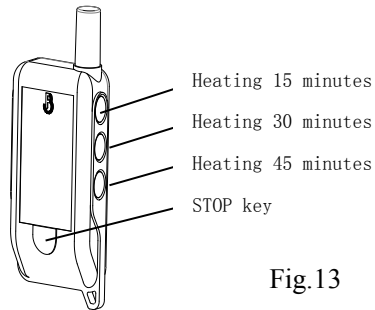

Fig.13

#### 5.5GSM remote controller(Optional function See Fig.14)

GSM remote controller is an extended function device of parking heaters which can be started and stopped through voice and SMS by phones or cellphones.It can start and power off heater immediately.

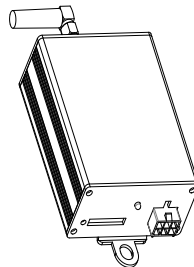

Fig.14

**Operation methods for remote controller and GSM controller please see relevant instructions.**

**Any consequences caused by not installing according our requirement we don't afford any responsibility**

## 6 Treatment of Usual Troubles

If the heater is started by an operator but it does not work properly, the operator can try the following methods for a treatment.

6.1 Turn off the heater and start it again. But pay attention. Do not re-start more than twice.

6.2 Check if the fuse connection between the battery and the heater is correct.

Protected circuit	Rated current of fuse	Rated current of fuse
	DC12V	DC24V
Warm air blower motor circuit	25A	
Main circuit of heater	20A	15A
Operation circuit of heater	5A	5A

6.3 If the temperature of cooling liquid is higher than  $70^{\circ}\text{C}$ , the heater can only be started after the temperature is reduced through pump circulation.

6.4 Trouble shooting can be eliminated according to the follow methods.

<b>Fault code</b>	<b>Fault cause</b>	<b>Troubleshooting methods</b>
10	Voltage overhigh	A Check power supply
11	Voltage overlow	A Check power supply B Charge the battery if voltage is low
12	Software overheat	A Check coolant level,refill coolant after temperature drop if lack of coolant and then start again  B Check whether water pump is working properly
14	Water temperature or overheating temperature difference overhigh	
15	Overheat lock 10 times	
17	Hardware overheat	
13	Second failure	A Check whether the fuel pipe is blocked or the fuel in the fuel tank is enough B Check whether air inlet pipe or exhaust pipe is blocked. C Check whether fuel mass is appropriate
20	Glow plug broke circuit	A Clean up the carbon deposition of glow plug
21	Glow plug short circuit	B Change glow plug C Change controller
30	The rotate speed of the fan is too high	A Change controller
31	The fan has a broken circuit	A Check whether fan wheel is binding B Change fan motor assembly C Change controller
33	The rotate speed of the fan is too low	A Check whether power voltage is too low B Check whether fan wheel is binding C Change controller
39	A short circuit of warm air blower	A Check motor of warm blower
41	A broken circuit of the water pump	A Check water pump line
42	A short circuit of the water pump	B Change water pump
47	There is a short circuit of the oil pump	A Check fuel pump leads connection is reliable
48	There is a broken circuit of the oil pump	B Change fuel pump C Change controller
50	Start failure lock over 10 times	Same as 13
51	Self-checking overhigh temperature of flame sensor	A Wait for flame sensor cooling B Change flame sensor(normal temperature resistance>about 1Ω)
52	Flameout 3 times	Same as 13
60	There is a broken circuit of the temperature sensor	A Check temperature sensor(normal temperature resistance is about 10Ω) B Change temperature sensor
61	There is a short circuit of the temperature sensor	
64	A broken circuit of the flame sensor	A Check flame sensor(normal temperature resistance is about 0.8Ω) B Change flame sensor
65	Flame sensor is short-circuited	
71	A broken circuit of the overheating sensor	A Check overheat sensor (power off protection switch)
72	Overheat sensor short circuit	B Change overheat sensor C Change controller
99	Fault information invalid	A Change controller
D3	Maintenance information	A Need to clean carbon deposition and maintenance work

## **7 Precautions**

7.1 Trial operation is necessary for the heater before it is put into normal use. If lasting dense smoke is observed or irregular combustion noise or fuel smell is sensed or overheating happens to electrical components, the heater must be turned off. Please take out the fuse, making the heater unable to operate.

The heater can only be put into use after it is tested by professional workers.

7.2 After power-on of the heater, the furnace does not ignite immediately. Ignition can only be started when the system self-testing is completed and the temperature of furnace cavity and temperature of cooling liquid are reduced to allowable level.

When the heater is turned off, the combustion supporting fan and water pump do not stop working immediately and they shall keep working for about one minute for purpose of heat dissipation

7.3 When you are going to add fuel, you have to turn off the heater in advance.

7.4 If any leakage is found in the fuel supply system, you should take the heater to an authorized customer service station for repair.

7.5 If the heater is left unused for long time, it shall be started once every month and work for ten seconds, to avoid blocking-up of pump or combustion supporting fan.

7.6 Attention: To avoid danger, when the cooling liquid becomes frozen, it is not allowed to start the heater.

7.7 If welding is carried out to the automobile, in order to protect the heater, you should disconnect the positive line of power supply from the battery and connect it to ground.

7.8 Only authorized customer service stations are allowed to provide repair and installation for the heater. It is prohibited to make repair by yourself or use non-manufacturer's parts or components so as to avoid danger.

7.9 The manufacturer shall not be held responsible for any damage to the heater if such is caused due to operations with violation against the regulations.

<b>Packing List</b>			
<b>No.</b>	<b>Name</b>	<b>Specification</b>	<b>Quantity</b>
1	Heater	YJH-Q5/1C、1Q、2C	1
2	Timer		1
3	Fuel pump	YB- I -12V(24V)	1
4	Muffler	XYQ- I	1
5	Wiring harness		1
6	Water pump	12V (24V)	1
7	Heater bracket		1
8	rubber cushion		4
9	Muffler bracket		1
10	Air inlet pipe	Φ20.5/Φ24 L=900	1
11	Exhaust pipe	Φ24/Φ29.5 L=1000	1
12	Positive wire of power supply		1
13	Fuse base	With cover	1
14	Fuse	QY169-5A	1
15	Fuse	12V/20A (24V/15A)	1
16	Fuse	QY169-25A	1
17	Water pipe	Φ17/Φ27 L=2600	1
18	Clip	16-25	1
19	Spring clip	Φ24×Φ27	10
20	Oil pump clip	Φ32	1
21	Oil pipe clip	8-10 (9-11)	12
22	Exhaust pipe clip	Φ24-28	3
23	Air inlet pipe fixing clip	Φ24 t=0.5	2
24	Exhaust pipe fixing clip	Φ27 t=0.8	2
25	Fuel pipe	GasolineΦ1.5×Φ4 (DieselΦ2×Φ5)	1
26	Fuel pipe connector	Φ3.5/Φ9.5 (Φ4.1/Φ10.5)	6
27	water pipe connector	Φ18 L=55	2
28	Special water pipe connector	PPA +33 Φ20×Φ18 L=60	2
29	Relay	4141(only for 12V)	1

<b>Packing List(Continue)</b>			
<b>No.</b>	<b>Name</b>	<b>Specification</b>	<b>Quantity</b>
30	Filter	RYL- I (only for diesel)	1
31	Bolt	M6×10	1
32	Self drilling tapping screw	ST5.5×25	6
33	Self drilling tapping screw	ST5.5×30	5
34	Self tapping screw	ST3×20	1
35	Self tapping screw	ST4×16	3
36	Spring washer	Φ6	2
37	Washer	Φ6/Φ12	2
38	Nut	M6	1
39	Fuel suction pipe	XYG- I 3×400	1
40	Plug	DJ7041A-2.8-21	1
41	Nylon cable ties	4×150	1
42	Nylon cable ties	4×200	1
43	Instruction manual		1
44	Reducing T	Φ6-Φ10/Φ10	1
45	Oil pipe clip	12-14	2
46	Non-return valve	D18	1
47	Transition elbow		2
48	Fixing gear		2
49	O-ring	14.8×2.62	2
50	Bolt	M6×95	1